

BA502



## THE INVISIBLE SOLUTION FOR HINGED GATES



There is but it is not seen because BA502 is under ground. And often underwater. But it is not a problem, because it is perfectly watertight and built with the best materials, aluminum, steel and bronze, without plastic inside.

It is also very compact, does not occupy the ground outside your property and the gate can be installed only 4.5 cm above the ground.

It is able to open very large and heavy doors in complete safety (in the 24v and 230v version with inverter) and will not push the doors in a dangerous way for your loved ones.

It is flexible, configurable with different prearrangement boxes and different leverages so as to adapt to your gate.

# BA502

## TECHNICAL SPECIFICATIONS

CODE	BA502	BA502/24V
<b>ELECTRICAL SPECIFICATIONS</b>		
POWER SUPPLY	230V 50Hz	24V cc
CURRENT (A)	1.4	3.2
POWER (W)	300	90
<b>PERFORMANCE DATA</b>		
SPEED (rpm)	1	1.2
TORQUE(Nm)	300	300
MAX. LEAF LENGTH(METERS)	2,5	2,5
<b>DIMENSIONAL AND GENERAL DATA</b>		
INGRESS PROTECTION (IP)	68	68
OPERATING TEMP (°C MIN/MAX)	-20 +50 °C	-20 +50 °C
DIMENSIONS (MM)	392x157x128	392x157x128
WEIGHT(KG)	15	14

### Installation reference

- [1] Blinker
- [2] Antenna
- [3] Key selector
- [4] Photocell transmitter
- [5] Control unit with radio receiver
- [6] BA502 gearmotor
- [7] BA502 gearmotor
- [8] Photocell receiver
- [9] Radiotransmitter
- [10] Second photocell receiver
- [11] Column for photocell
- [12] Second photocell transmitter
- [13] Column for photocell

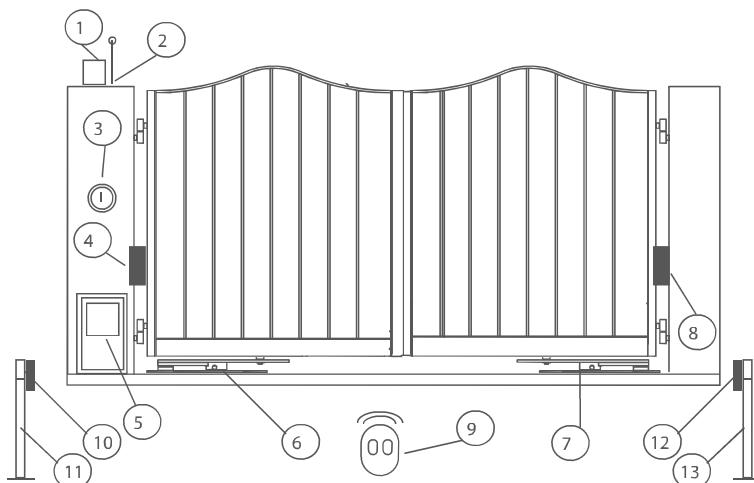

### DIMENSIONS

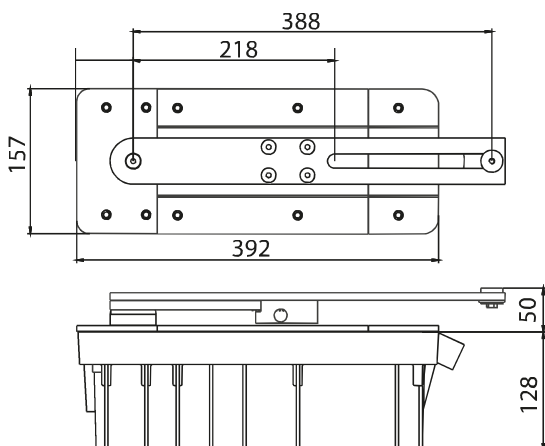

### ACCESSORIES



BOX/002  
galvanized steel  
foundation box



BOX/003  
stainless steel  
foundation box



BOX/004  
self-supporting  
foundation box



BOX/006  
galvanized heavy seal  
foundation box



COVER/502  
stainless steel  
finishing plate  
for BOX002/003



COVER/502 PLUS  
stainless steel  
finishing plate  
for BOX006



FCM  
Mechanical limits  
for BOX006



SOLAR/24  
Solar charger